

FeONIC F4 Audio Drive

FeONIC F-Drives can be used to convert new and existing structures of commonly used resonant building materials into high quality loudspeakers. The structural surface performs as a highly intelligible powerful distributed mode (non-directional) speaker suitable for both audio reproduction and public address systems, satisfying the EN60849 standard for acoustic quality in public places.

The F-Drive is unlike traditional speaker technology because it uses a very high powered magnetostrictive smart material as the driver instead of a moving coil. The material was originally developed by the US military for sonar applications and is now de-restricted for commercial use. The magnetic field that causes the smart material inside the sounder to react is created by drive coils around the material. The smart material sounder exhibits much superior properties over conventional speaker technologies.

Key Features

Plug and Play compatibility
Massive output force
Wide frequency bandwidth
Robust solid state technology with Long service life – (no moving parts)
No speaker grille required
Precise control
Production stable
Wide temperature range
Impervious to moisture damage
Mono, stereo, 2.1/5.1/7.1/9.1

Technical Specification

Impedance:	4 Ohms
Integrated Circuitry:	2 way crossover & circuit protection
Operating temperature range:	-20°C to +80°C* (-50°F to 176°F)
Storage temperature range:	-20°C to +100°C* (-50°F to 212°F)
Weight:	c370g
Dimensions:	76.5mm (W) x 46mm (L) x 26mm (H)
Mounting method:	3M VHB adhesive
Connection to amplifier:	Flylead with 1.5m cable
Recommended amplifier power rating¹:	20Watt
	Typical power consumption 10Watt
Sensitivity²: (glass³)	63dBA @ 1m
Sensitivity²: (MDF⁴)	67dBA @ 1m
Typical Bandwidth:	100Hz-20,000Hz
Sound Pressure Level⁵: (glass³)	Peak 89dBA (SPL 85dBA) @ 1kHz 1m
Sound Pressure Level⁵: (MDF⁴)	Peak 89dBA (SPL 85dBA) @ 1kHz 1m
Speech Transmission Index / Common Intelligibility Scale⁶:	0.60 to 0.75 / 0.78 to 0.88
Environmental protection:	IP55 (Impervious to moisture damage ^{**})

¹Recommended amplifier power rating for optimum performance, ²Sensitivity measured with 1kHz sine wave at 1Watt, ³Reference glass panel size 10mm x 1m x 1m, ⁴Reference MDF panel size 18mm x 1m x 1m, ⁵Max Sound Pressure Level (SPL) achieved with sounder mounted on same side as measurement with 1kHz sine signal before circuit protection is triggered, ⁶STI/CIS values, measured to IEC Standard 60268-16, are typical values since it is dependent on acoustics of installation site. *High temperature variants available on special order. **Cannot be immersed



Typical Applications

PA and background music applications for public places – glass, plasterboard, aluminum, steel composite board, wood floors, MDF etc

Transport systems - embedded into bus shelters, surface claddings, buses and train interiors

Invisible audio – embedded audio-floors in clubs, Grade 1 listed buildings and domestic sound systems

Whispering Window® – proven retail promotion tool (sales uplift of >50%), Windows in hospitality suits and stadia, patio doors, smoking shelters, 2 way communications through security screens

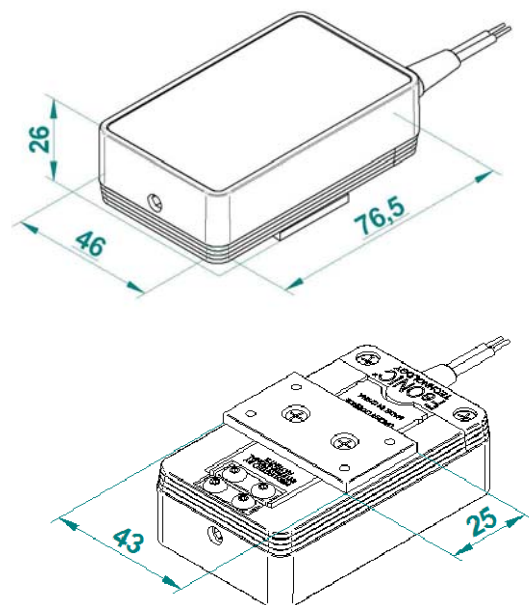

Speech intelligibility

PA systems require high intelligibility. EN 60849/1998 requires higher levels of intelligibility and clarity for public places. FeONIC F-Drives provide a more even distribution of sound than directional traditional speakers - the whole panel becomes the speaker cone, creating an omnidirectional, evenly distributed output. The frequency response of the output is not affected by the position of the listener relative to the sounder so all valuable speech information is communicated unlike directional solutions.

The F-Drive can also be driven at low volumes, filling greater spaces more consistently than directional speakers with much less echo.

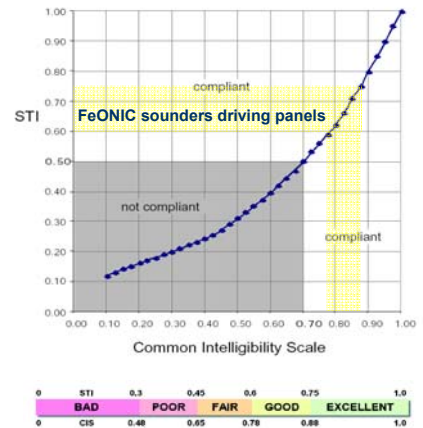

Reference Glass Panel

Reference MDF Panel

Frequency Response for Pink noise at max SPL

